

NEW WISDOM Miner’s Cap Lamp Booklet

KL5M LED Li-ion Cap Lamp
 NWB-15 Portable Charger
 NWCR Series Charger Rack for KL5M LED Cap Lamp
 Summary of the advantages of the products are
 Usage, Maintenance and Safety Notes
 KL5M Parts Drawing
 CE Certification KL5M
 CE Certification NWB-15

TABLE OF CONTENTS

KL5M LED Li-ion Cap Lamp	2
Product Features:	2
Technical Parameter and Specifications:	3
NWB-15 Portable Charger	3
Usage Guide:	3
Maintenance:	4
Charging Theory:	4
Technical Specifications:	4
Packaging Specifications for the KL5M and NWB-15	4
NWCR Series Charger Rack for KL5M LED Li-ion Cap Lamp	4
Technology parameter:	5
Usage Guide:	6
Notes:	6
Charging Chart:	7
Charger Rack Design Schematic:	7
Summary of the advantages of the products are:	7
Usage, Maintenance and Safety Notes:	8
The Li-ion Battery:	8
The Head Lamp	8
Users Guide	8
Maintenance	9
Troubleshooting	9
KL5M part drawing	10
CE Certification KL5M	11
CE Certification NWB-15	12

KL5M LED Li-ion Cap Lamp

The innovatively designed KL5M LED Li-ion Cap Lamp combines the latest lighting and battery technologies to result in a brighter and lighter cap lamp. Using lithium-ion technology in conjunction with a purpose designed LED the cap lamp is designed in accordance with the Restriction of Hazardous Substances Directive (RoHS). The KL5M is not only much smaller and ergonomically designed for wearer more comfortable than the traditional lead acid cap lamp, and they are one third of the weight at only 0.6kg. The use of lithium-ion technology also removes numerous hazards associated with the use of lead acid style batteries. Unlike traditional lead acid batteries, lithium-ion contains no dangerous chemicals or heavy metals and requires no maintenance such as topping up of acid. The KL5M significantly reduces cost of ownership with no requirement to replace bulbs and a service life three times longer than lead acid batteries. The cap lamp is also intrinsically safe and CE Certified (EN60079-0:2004, EN62013.1:2002, EN50020:2002, EN50033:1991) for use in explosive atmospheres.



The KL5M was first introduced to the market in 2003 and has undergone constant refinements and improvements. The cap lamp is designed to withstand the harshest underground conditions and is manufactured from impact and temperature resistant Makrolon plastic material. The KL5M when fully charged holds its charge until use and will provide 15 hours of continuous light. To prolong the life of the cap lamp battery, the Lithium-ion battery has an over charge protection system that will automatically cut off the circuit to protect the battery from being over charged. Additionally, there is an automatic power off in the cap lamp so that if the surface of the lamp or the LED is broken it will automatically turn the power off for protection.



The 2007 version of the KL5M LED Li-ion Cap Lamp has many improved features from its predecessor. A purpose designed LED with an upgraded antistatic capacity provides luminous flux of 90-120lm and increased brightness at 7,000-11,000lux. A new radiator in conjunction with the purpose designed LED has significantly reduced the amount of heat experienced at the glass. In addition, the cap lamp's flood and spot light settings are operated by an upgraded push button. As an added safety feature the cap lamp now also incorporates a low battery warning with the last hour of discharge flashing every 5-10 seconds to warn the user. And the version 2008 is mainly improved base the version 2007 to make the lamp absolutely water proof and better usage with the button switch. In 2009, we improved the lamp with new flexible cable even in very cold weather so that it is comfortable to be used by the miners especially for the miners of the cold weather. The KL5M LED Li-ion Cap Lamp has set a new standard in reliability and safety for miner's cap lamps.

NOTE: we have patent of the lamp design, the patent No. is ZL 2006 3 0176325.1

Product Features:

Safety: Contained in a sealed battery case, the product has a short-circuit protection, LED light head lamp and anti-static housing which makes it explosion proof. The miner's lamp is CE Certified for use in explosive atmospheres such as coal mines.

Reliability: Tough housing, optimized design, a solid LED light that uses high efficient IC drivers guarantee the product is durable and strong. The durable Li-ion battery has an over charge protection system to protect the battery from over charging. The cap lamp is suitable for operation under harsh mining conditions.

Portability: Small in size, light in weight, ergonomically designed, maintenance free, simple charging, easy operation. The cap lamp has received praise from many miners and major mining companies.

Efficiency: LED light provides bright, clear, white light. The minimum luminous intensity is 7000-11000lux (at a distance of 1m). The quality of the light is maintained throughout the entire discharge cycle which lasts up to 15 hours. The battery has a life cycle of 1200 charges and discharges.

Environmental: The cap lamp is made from environmentally friendly Li-ion battery and other non hazardous materials. The KL5M is an environmentally friendly product as per RoHS Directive.

Economy: The cap lamp incorporates an environmentally friendly LiMn2O4 battery as a power source. The light is an efficient, high powered LED with a service life of over 30,000 hours. With no need to replace incandescent globes the KL5M eliminates the cost of labor and replacement parts associated with traditional lead acid batteries.

Technical Parameter and Specifications:

Features	KL5M Specifications
Rated capability	>5.5Ah (5.5-6.9Ah LiMn2O4 Li-ion battery)
Rated voltage	3.8V
Continuous discharging time	15h (12-20h)
Main light LED Working voltage	3.3V
Main light LED Working current	0.37A (0.35-0.39A)
Main light Power	1W
Main light Luminous flux	110Lm (90-120Lm)
Lamp lighting degree Initial Lighting degree	10000Lux (11000-7000Lux) (distance in 1 m)
Lamp lighting degree Lighting degree in 11 hours	10000Lux (11000-7000Lux) (distance in 1 m)
Main light Usage life hour	>30000h
Accessory light Power	0.4W
Accessory light Usage life hour	>20000h
Short circuit protect time	<320µS
Usage duration of battery (recharges)	1200 recharges (in reasonable working condition)
Charging time	6h-8h
Dimensions	78 x 31 x 79mm (size of the Li-ion battery)
Weight	0.6kg

NWB-15 Portable Charger

The NWB-15 Portable Charger is a desk top charger specifically suited for the NEW WISDOM KL5M LED Li-ion Cap Lamp. The charger provides the user with the ability to charge the cap lamp from a standard power outlet. It is small in size, light in weight, and convenient to carry. The newly designed NWB-15 Portable Charger is more reliable than previous models and has a simple, sleek finish. The circuit board design has been optimized and improved to increase safety and reliability. The charger’s shell is made from high quality aluminum alloy. The NWB-15 is CE Certified for European Union standards. In 2008 Nov. we have improved the portable charger combined with 85-265V/AC and 6-30V/DC charging function. Customers also can have the charger with 85-265V/AC charging function only.

Usage Guide:

1. The charger is compatible with most standard power outlets; the charger is supplied with an input voltage of 85- 265V and a frequency range

NWB-15



of 50-60Hz. You also can have the additional charging function of 6-30V/DC in this same charger.

2. Outlet plugs can be supplied for US, EU, UK and AU standards.
3. Connect the outlet plug to the power outlet; the charger indicator light will turn green to indicate the presence of power.
4. Place the cap lamp head into the plug of the charger; turn 180 degrees clockwise until the anode contacts with the charger's cathode; the charger indicator light will turn red to indicate it is charging.
5. Once charging is completed the charger indicator light will turn green. The charging time is approximately 6-12 hours.

Maintenance:

The NWB-15 Portable Charger requires no maintenance if used correctly under standard operating conditions.

Charging Theory:

The Lithium-ion battery makes use of both constant current and constant voltage charging methods. The charging current is 1500mA ±150mA; voltage is 4.30V ±0.05V with an approximate charging time of 6-12 hours. The circuit is designed with a steady state charging and control system which automatically regulates the charging process. The circuit we design is near the theory charging for Li-ion battery. For a discharged battery a constant current charge is employed at 1500mA ±150mA (the charger indicator light is red). When the charging voltage reaches 4.30V, the battery switches to a constant voltage charge (at this point the battery is approximately 70% charged) and the current gradually decreases. When the battery is sufficiently charged it automatically cuts off the circuit to protect the battery from over charging (the charger indicator light is green).

Note: It is not necessary to wait until the battery is completely discharged before charging. Charging can be undertaken whilst the battery is at any capacity and it actually prolongs the life span of the battery if charging is completed prior to complete discharge.

Technical Specifications:

1. Input: 85-265V /AC, 50-60Hz, 1A
Or 6-30V/DC, 2A
2. Output: 4.30 ±0.05V /DC, 1500mA ±150mA
3. Size: 125 x 55 x 80mm; weight: 0.3kg
4. Plug: US, EU, UK or AU standards for different markets.

Packaging Specifications for the KL5M and NWB-15

NAME	DESCRIPTION	SPECIFICATION	PACKING	REMARK
KL5M	Li-ion Cap Lamp	78 x 31 x 79mm(battery), 0.6kg	43.5 x 36 x 21cm 20pcs, 14kg	Carton
NWB-15	Single unit portable charger; 85-265V, 50-60Hz	125 x 55 x 80mm 0.30kg	43.5 x 36 x 21cm 30pcs, 11kg	Carton

NWCR Series Charger Rack for KL5M LED Li-ion Cap Lamp

The NWCR series charger rack is specially designed and manufactured for multi-charging of the NEW WISDOM KL5M LED Li-ion Cap Lamp. The new charger rack employs an optimized circuit design for increased reliability. The charger rack structure is manufactured by a digital control machine which ensures precision and a sleek, uncomplicated finish.

NWCR-102

Features:

- a. Incorporates an advanced switch power supply, no transformer required; automatically regulates the charging process, ease of use and minimal maintenance, saves time and labor, reduced operating costs compared to traditional lead acid battery chargers.
- b. No requirement to monitor each cap lamp individually, automatically changes from constant current to constant voltage charge, automatically regulated charging, automatic cut off protection from over charging.
- c. High power efficiency charging saving time and energy, minimal increase in the temperature of the Li-ion battery ensuring a longer life for the lamp compared to using other charging equipment.
- d. Specialized circuit design makes it suitable for a wide range of voltage inputs. The charger rack has internal protection from voltage spikes and operates over a wide voltage range.
 - e. No requirement to have a ventilated battery storage area as necessary with traditional lead acid battery charging stations.

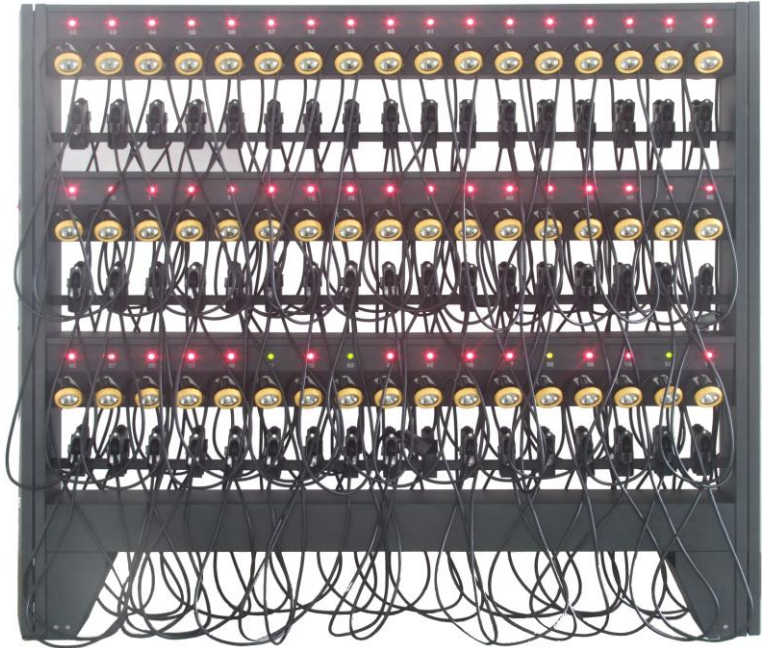

NWCR-36



Charging Theory:

The Lithium-ion battery makes use of both constant current and constant voltage charging methods. The charging current is 1500mA ±150mA; voltage is 4.30V ±0.05V with an approximate charging time of 6-12 hours. The circuit is designed with a steady state charging and control system which automatically regulates the charging process. For a discharged battery a constant current charge is employed at 1500mA ±150mA (the charger indicator light is red). When the charging voltage reaches 4.30V, the battery switches to a constant voltage charge (at this point the battery is approximately 70% charged) and the current gradually decreases. When the battery is sufficiently charged it automatically cuts off the circuit to protect the battery from over charging (the charger indicator light is green).

Note: It is not necessary to wait until the battery is completely discharged before charging. Charging can be undertaken whilst the battery is at any capacity and it actually prolongs the life span of the battery if charging is completed prior to complete discharge.

Technology parameter:

Number	Input	Output	Total Power	Capacity
NWCR-102	85-265V, 50-60Hz, 20A	4.30V ±0.05V, 1.5Ax102	1500W	102 units
NWCR-60	85-265V, 50-60Hz, 12A	4.30V ±0.05V, 1.5Ax60	1000W	60 units
NWCR-36	85-265V, 50-60Hz, 8A	4.30V ±0.05V, 1.5Ax36	500W	36 units
NWCR-24	85-265V, 50-60Hz, 5A	4.30V ±0.05V, 1.5Ax24	360W	24 units
NWCR-12	85-265V, 50-60Hz, 3A	4.30V ±0.05V, 1.5Ax12	180W	12 units

Note: Charger racks can be custom designed for different sizes and recharge capacities.

Number	DESCRIPTION	CHARGER RACK	PACKING	REMARK
NWCR-102	102 units Li-ion battery miner's lamp charger rack	185 x 36 x 171cm, 175kg	192 x 176 x 41cm, 250kg	wooden case
NWCR-60	60 units Li-ion battery miner's lamp charger rack	115 x 36 x 171cm, 125kg	122 x 176 x 41cm, 180kg	wooden case
NWCR-36	36 units united compact style charger rack	86 x 98 x 23cm, 47kg	88 x 100 x 25cm, 53kg	Carton
NWCR-24	24 units united compact style charger rack	58 x 98 x 23cm, 34kg	60 x 100 x 25cm, 38kg	Carton
NWCR-12	12 units module compact style charger rack	30 x 98 x 23cm, 19kg	32 x 100 x 25cm, 23kg	Carton

Usage Guide:

- a. Before connecting to the main power, please ensure that all visible wires are tightly connected and there is no part loosen or has been damaged in the transportation. When it is certain everything is normal then the charger rack can be connected to the main power.
- b. To connect the 85-265V, 50-60Hz main power to the outlet on the charger rack. Please ensure that the power is connected firmly and is the correct configuration for the usage. Please ensure the main power is off when connecting to the outlet.
- c. Turn the power on to test if the charger rack is working correctly. When first testing do not have any cap lamps on the charger. With the power on the input voltage displayer will display the main power voltage; all the charger indicator lights should be green. Next test the charger with the cap lamps on the charger. Place the cap lamp head on the point and turn 180° clockwise to ensure the charger and the lamp are firmly touching the cathode and anode. If the charger indicator light is red this means the cap lamp is charging normally. Repeat this test wit all other cap lamps at each individual charge point.
- d. If the cap lamps are placed on the charger rack with various charges remaining, the charging times will be different. Accordingly, the charger indicator lights may not display the same colors. When the charger indicator light is green the cap lamp is finished charging. The normal charging time is between 6 to 8hours.

NWCR-24



Notes:

- a. Ensure that the supply voltage does not exceed the rated voltage otherwise the chargers voltage protection system will automatically cut off the main power.
- b. If the voltage fluctuates outside the 85-265V, 50-60Hz range the charger will power off. When the power return to the correct operating range the power will come back on and will continue charging the cap lamps. There is no need to remove the cap lamp if this occurs.
- c. Should the charging time be longer than the stated charging time, please check for any loose connections between the lamp and the rack and inside the rack.
- d. Li-ion batteries require a specific charger. They require high precise constant voltage and constant current at specified rates. Different manufactureş use varying parameter for their Li-ion battery cap lamp and are not compatible with our lights.

Charging Chart:

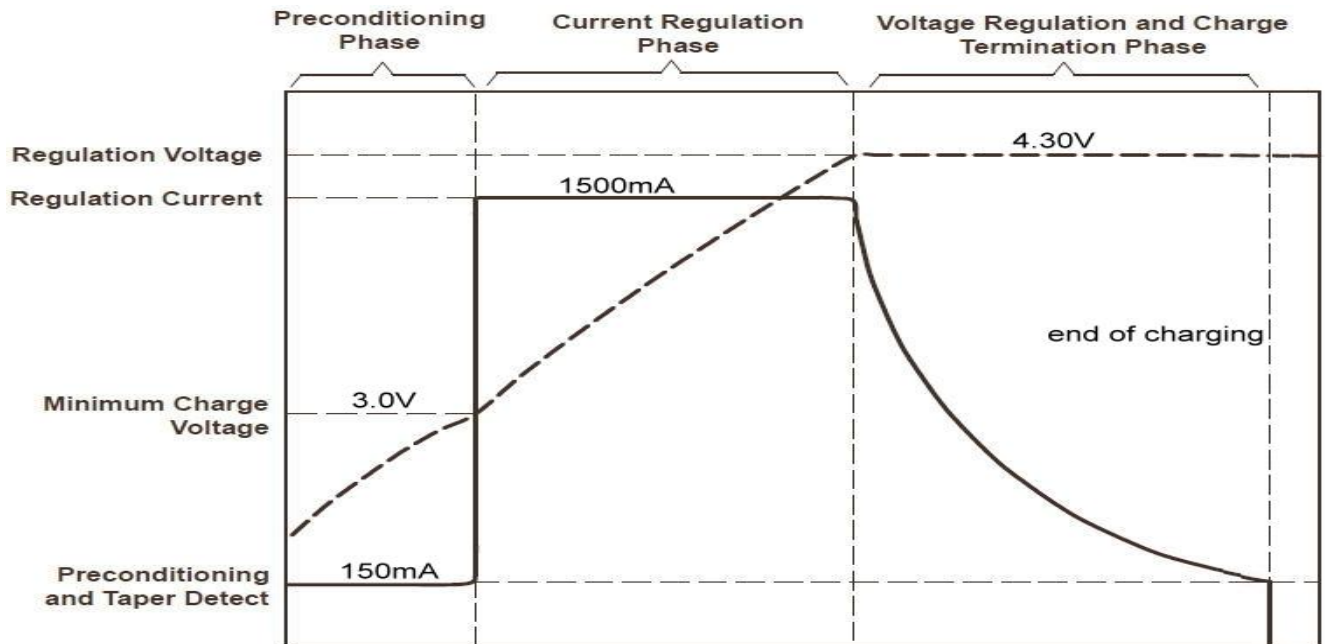

Charger Rack Design Schematic:

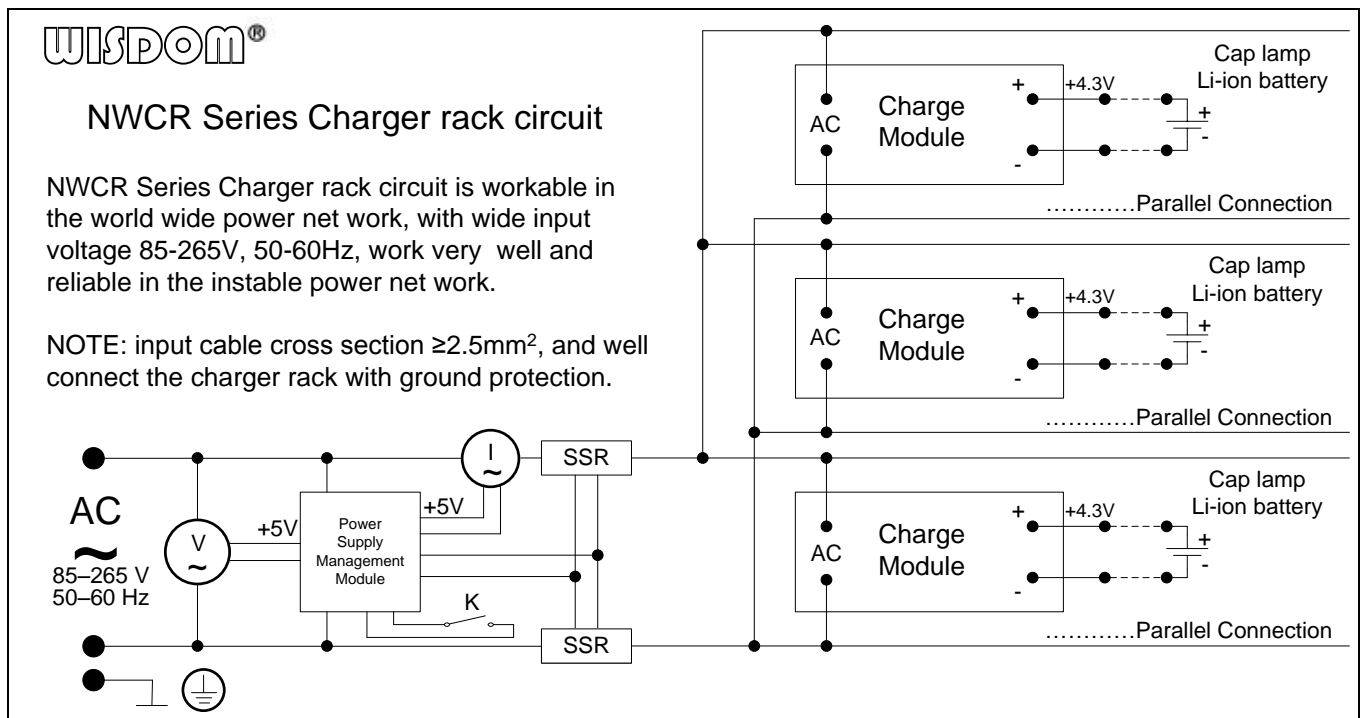

Summary of the advantages of the products are:

1. The LED is specially designed for only us, the chip is made in a big radiator which well deals with the heating. 90% and up of other LED in the market are made in a very small radiator then connect the legs of the LED to an aluminum pcb as radiator which will be a problem as we research for a long time because there will be a gap between the LED and aluminum pcb after a certain time of usage, hence seriously affect the heating radiator, and hence accelerating the decay ratio of the LED. Our LED light is the latest version of 90-120lm to make the brightness of the lamp to be more than 11000lux in one meter.
2. with the minding function in the last hour by flashing softly in each 5-10seconds so that user can well use the balance time of the lamp. It is very good for the miners use our lamp in the mine.
3. Our power source is also specially made for us only. It is Li-ion battery of LiMn2O4 material which is the most safety with

5.5-6.9Ah capacity, light weight, small size.

4. The plastic parts of our lamp are made from famous German brand--Bayer PC material. This way is to make our lamp can bear the heat to 120 degrees, very good quality, anti-attached, not easy to deformation, durable, good looking and feels well.

5. The APCBs of the head lamp, the battery and the charger are designed by us. We have skilful and experienced engineers to design the APCB in the best working situation for the mines and for our lamps and chargers. This way we can well control the quality and improve the function frequently whenever better new ideas come up, including applying better components whenever available and improved the circuit design.

6. We frequently improve the design of the APCBs by modifying the circuit designs.

Now the APCB of the charger is near the charging theory for the Li-ion battery;

The APCB for the cap lamp with minding function and very good working functions too;

The APCB for the battery is very safety, high efficient with many protection function.

7. We have strict testing of our product so that we can make sure the quality is in good situation. For example, we use 1.5 atmosphere pressures to test the lamps working under the water. Since 2006 to now, we have test for thousands of times and adjusted SOP of 18 times for the technical of production and 62 times modules of parts, finally we have made the lamps absolutely water proof since six months ago. And we will continue monitor the quality by testing and keep the Lean Production statue.

8. We have our own advanced injection machine to make the plastic parts so that we can make sure to use the best materials to make the parts and we can inspect the production of the plastic parts to make the plastic parts better quality.

9. We use all stainless steel to make the metal parts for best quality possible.

10. We have applied the production management of 5S; so that we can make sure the workers are strictly produce the goods to our requirements strictly.

11. We keep improving our quality as your back up so that you can feel release to open the market in the best way.

Usage, Maintenance and Safety Notes:

The Li-ion Battery:

- a. The Li-ion battery is made from LI, NI, MN, CO and compound oxide as the anode, and the cathode is made from the graphite and coke material etc.
- b. In the center is the septum which is made from the PP/PE/PP compound membranes. After filling the anhydrous electrolyte then the whole battery house is sealed.

The Head Lamp

The head lamp is including in the housing, LED, spherical reflector, and lamp headpiece glass convex, the connection of charge of anode and cathode and the power button.

Users Guide

1. Preparation before using

Inspect all lamps for any damage before using them. Also ensure that all the documents such as the technical specifications booklet, the user's guide and the production certificate are in place.

2. Initial charging

Li-ion batteries do not require an initial charging and will hold a charge indefinitely once charged.

3. Daily charge

The daily charge is based on the constant current and constant voltage fundamental (CC/CV). If utilizing the charger rack, the charging voltage is $4.30 \pm 0.05V$ and the charging current is 1.5A at the beginning dropping to almost zero (less than 0.15A) at the end of the charge.

To charge the cap lamp follow these steps:

- a. When the lamps reach the charge room, put them on the charge rack one by one---put the charging point of the lamp on the plugs of the rack and turn 180° clockwise till the charger and the lamp firmly connect with the cathode and anode. The charger LED indicator turn red indicating that charging is occurring normally.
- b. The time to complete a charge for the 5.5Ah Li-ion battery is between 6 to 8hours. At the end of charging, the charger LED indicator light will turn green.

4. Guidance for charging:

- a. Generally the cap lamp is used daily and will require a daily charge. The charging current is 1.5A and the charger indicator light is red on commencing charging. If the indicator light is not red ensure that the cap lamp is not almost fully charged or there is a bad contact between the charger and the head lamp.
- b. Once the cap lamp is fully charged it is not necessary to remove them from the charger rack. Also, the power can remain on to the charger rack at all times. The Li-ion battery over-charge protection system will automatically cut off power to the charging circuit to protect the battery from any damage due to over charging.

5. Using the cap lamp underground:

If the lamp short circuits during normal use, the protection circuit will immediately cut power to the lamp within 15ms. After the fault has been rectified, the lamp is safe for use.

- a. Please do not store lamps in an environment with temperature above 60°C.
- b. The lamps should be stored at room temperature in a dry environment (use an air conditioner room for humid climates). If you need to stock them for a long time, please charge them once one to two months to at least 50% capacity.

Maintenance

Opening the cap lamp battery housing will void all warranty on the product. Please be aware that the parts of the Li-ion battery are in a sealed housing and must not be opened under any circumstances. Should the battery require maintenance, please contact the manufacturer or your sales representative. **DO NOT ATTEMPT TO FIX THE BATTERY BY YOURSELF.** The LED light may be opened if not working properly. Please follow the steps below to service the head lamp:

1. **Open the head lamp;** use the triangle key to unscrew the safety screw to open the head lamp cover.
2. **Remove parts;** remove the head lamp glass cover, sealed ring of the head lamp cover and the light parts to access to the inside of the head lamp.
3. **Checking inside of the head lamp;** after removing the head lamp parts you can check the inside of the head lamp for damage.
4. **Checking charging connection:** Use the furcation screw puller to remove the screw on the charging connection, remove the cap clip, secure spring piece, charger switch, and the insulated plastic piece. Ensure the charger connection point is in good condition.
5. **Checking main cable:** Use the spanner to remove the screw which holds the cable to the head lamp. Use the screwdriver to pull down the welding piece on the edge of the cable, loosen the drag resistance cord, and gently pull down the cable from the head lamp. If the cable inside the head lamp is damage, cut 30mm below the damaged part of the cable. To make a new connection twist together 8mm from the top of the cable. Weld new welding piece on the top of the cable, and then connect with anode and cathode, be careful not to swap the terminals.
6. After checking as above, assemble the head lamp again in reverse order and test.

Troubleshooting

If there is a fault during normal operation of the cap lamp, please first troubleshoot the problem by following the common problems and potential solutions found below:

1. Battery life is short:

Cause	Solution
Not adequately charged	Check the charge points are in good condition then charge as specified in this booklet.
KL5M: working current is 0.37A (0.35-0.39A)	The KL5M Cap Lamp LED does not need replacement.

2. Current is too low or no current when charging:

Cause	Solution
Loose connection points increasing the resistance	Check that all the connection points and fix as necessary
Cut off inside the cable	Follow Step 5 in Maintenance for cutting of section of the cable.

3. Charging current is high at the end of charging and battery is hot:

Cause	Solution
Bad insulation on the outside of the lamp is causing a short circuit	Check the condition of the battery housing.

Short circuit inside the battery storage	Contact manufacturer or sales representative.
Inside the head lamp the anode and cathode connect incorrectly	Follow Step 4 in Maintenance to ensure head lamp is in correct condition.

4. Head lamp can't rotate freely on charge plug

Cause	Solution
Charge switch inside the head lamp is broken	Follow Step 4 in Maintenance and replace the charge switch.

KL5M part drawing

NEW WISDOM KL5M PART DRAWING for KL5M since 2008.06 parts for the head lamp

- 1. head lamp cover**
- 2. head lamp glass**
- 3. sealed ring of the head lamp cover**
- 4. reflector**
- 5. LED light (main LED and accessory LED)**
- 6. radiator**
- 7. button united parts**
- 8. main circuit board**
- 9. head lamp shell**
- 10. nut, mat, sealed ring to fix the cable**
- 11. cap lamp clip united parts**
- 12. lock screw of the head lamp cover**
- 13. main cable**
- 14. cover of the battery shell**
- 15. sealed ring of the battery shell**
- 16. 5Ah Li-ion battery with protective board**
- 17. battery shell**

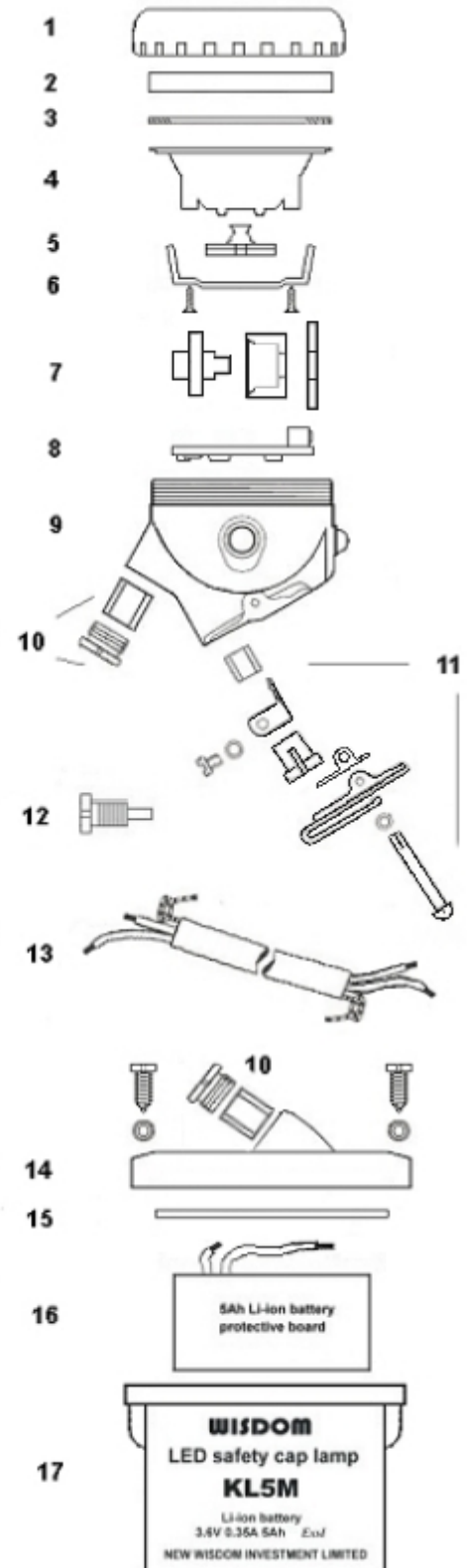

2008.06

CE Certification KL5M

Bontek Compliance Laboratory

CE Certification of Conformity

Certification number: BCT06KC068S Report number: BCT06KR068S
Bontek Compliance Laboratory Ltd hereby declares that testing has been completed and reports have been generated for:

Applicant: NEW WISDOM INVESTMENT LIMITED
4-306, Xianglixincun, Hongli West Road, Shenzhen, China

Manufacturer: NEW WISDOM INVESTMENT LIMITED
Building A1-4, Shenbao Industry Park, Longgang district, Shenzhen, China

Product: Miner's cap lamp
Model: KL5M
Power rating: Input: 3.3VDC 0.35A

And, in accordance with the following Applicable Directives:

**94/9/EC ATEX Manufacturers Directive (as amended)
Electrical and non-electrical equipment**

That this product has been assessed against the following Applicable Standards:

ATEX EN 60079-0: 2004 Electrical apparatus for explosive gas atmospheres general requirement

Therefore, Bontek Compliance Laboratory Ltd hereby acknowledges that the applicant may issue a DECLARATION of CONFORMITY and apply the CE marking in accordance with European Union Rules.

Attestation by: 
Andrew He Date of issued: November 1, 2006



Rm 802-804, Jinmin Bld., Zizhu 6th Rd., Zhuzhi Lin, Futian, Shenzhen 518040, Guangdong, P. R. China
Tel: 86-755-82871080 Fax: 86-755-82871368 Http://www.bontek.com.cn

Bontek Compliance Laboratory

CE Certification of Conformity

Certification number: BCT06KC070S Report number: BCT06KR070S
Bontek Compliance Laboratory Ltd hereby declares that testing has been completed and reports have been generated for:

Applicant: NEW WISDOM INVESTMENT LIMITED
4-306, Xianglixincun, Hongli West Road, Shenzhen, China

Manufacturer: NEW WISDOM INVESTMENT LIMITED
Building A1-4, Shenbao Industry Park, Longgang district, Shenzhen, China

Product: Miner's cap lamp
Model: KL5M
Power rating: Input: 3.3VDC 0.35A

And, in accordance with the following Applicable Directives:

**94/9/EC ATEX Manufacturers Directive (as amended)
Electrical and non-electrical equipment**

That this product has been assessed against the following Applicable Standards:

ATEX EN 62013-1: 2002 Cap lights for use in miners susceptible to fire/explosion general requirements — construction and testing in relation to the risk of explosion

Therefore, Bontek Compliance Laboratory Ltd hereby acknowledges that the applicant may issue a DECLARATION of CONFORMITY and apply the CE marking in accordance with European Union Rules.

Attestation by: 
Andrew He Date of issued: November 1, 2006



Rm 802-804, Jinmin Bld., Zizhu 6th Rd., Zhuzhi Lin, Futian, Shenzhen 518040, Guangdong, P. R. China
Tel: 86-755-82871080 Fax: 86-755-82871368 Http://www.bontek.com.cn

Bontek Compliance Laboratory

CE Certification of Conformity

Certification number: BCT06KC071S Report number: BCT06KR071S
Bontek Compliance Laboratory Ltd hereby declares that testing has been completed and reports have been generated for:

Applicant: NEW WISDOM INVESTMENT LIMITED
4-306, Xianglixincun, Hongli West Road, Shenzhen, China

Manufacturer: NEW WISDOM INVESTMENT LIMITED
Building A1-4, Shenbao Industry Park, Longgang district, Shenzhen, China

Product: Miner's cap lamp
Model: KL5M
Power rating: Input: 3.3VDC 0.35A

And, in accordance with the following Applicable Directives:

**94/9/EC ATEX Manufacturers Directive (as amended)
Electrical and non-electrical equipment**

That this product has been assessed against the following Applicable Standards:

ATEX EN 50033: 1991 Specification for construction and testing of miners' cap lamps in relation to the risk of explosions, for mines susceptible to fire/explosion

Therefore, Bontek Compliance Laboratory Ltd hereby acknowledges that the applicant may issue a DECLARATION of CONFORMITY and apply the CE marking in accordance with European Union Rules.

Attestation by: 
Andrew He Date of issued: November 1, 2006



Rm 802-804, Jinmin Bld., Zizhu 6th Rd., Zhuzhi Lin, Futian, Shenzhen 518040, Guangdong, P. R. China
Tel: 86-755-82871080 Fax: 86-755-82871368 Http://www.bontek.com.cn

Bontek Compliance Laboratory

CE Certification of Conformity

Certification number: BCT06KC069S Report number: BCT06KR069S
Bontek Compliance Laboratory Ltd hereby declares that testing has been completed and reports have been generated for:

Applicant: NEW WISDOM INVESTMENT LIMITED
4-306, Xianglixincun, Hongli West Road, Shenzhen, China

Manufacturer: NEW WISDOM INVESTMENT LIMITED
Building A1-4, Shenbao Industry Park, Longgang district, Shenzhen, China

Product: Miner's cap lamp
Model: KL5M
Power rating: Input: 3.3VDC 0.35A

And, in accordance with the following Applicable Directives:

**94/9/EC ATEX Manufacturers Directive (as amended)
Electrical and non-electrical equipment**

That this product has been assessed against the following Applicable Standards:

ATEX EN 50020: 2002 Electrical apparatus for potentially explosive atmospheres- Intrinsic safety "i"

Therefore, Bontek Compliance Laboratory Ltd hereby acknowledges that the applicant may issue a DECLARATION of CONFORMITY and apply the CE marking in accordance with European Union Rules.

Attestation by: 
Andrew He Date of issued: November 1, 2006



Rm 802-804, Jinmin Bld., Zizhu 6th Rd., Zhuzhi Lin, Futian, Shenzhen 518040, Guangdong, P. R. China
Tel: 86-755-82871080 Fax: 86-755-82871368 Http://www.bontek.com.cn

CE Certification NWB-15 (GWB-15)



Bontek Compliance Laboratory

CE Certificate of Conformity

Certification number: BCT07AC-044S Report number: BCT07AR-044S

Bontek Compliance Laboratory Ltd hereby declares that testing has been completed and reports have been generated for:

Applicant: **NEW WISDOM INVESTMENT LIMITED**
4-306, Xianglixincun, Hongli West Road, Shenzhen, China

Manufacture: **NEW WISDOM INVESTMENT LIMITED**
Building A1-4, Shenbao Industry Park, Longgang District, Shenzhen, China

Product: **PORTABLE CHARGER**

Model: **GWB-15**

Rating: **Input: 110-240VAC, 6W**

Note: --

And, in accordance with the following applicable directives:
73/23/EEC Low Voltage Directive (as amended)

That this product has been assessed against the following applicable standards;
LVD EN 60335-2-29

Therefore, Bontek Compliance Laboratory Ltd hereby acknowledges that the applicant may issue a DECLARATION of CONFORMITY and apply the CE marking in accordance with European Union Rules.

Attestation by: 



Andrew He Date of Issued: January 25, 2007

Rm 802-804, Jinmin Bld, Zizhu 6th Rd., Zhuzi Lin, Futian, Shenzhen 518040, Guangdong, P. R. China
Tel: 86-755-82871080 Fax: 86-755-82871368 Http://www.bontek.com.cn



Bontek Compliance Laboratory

CE Certificate of Conformity

Certification number: BCT07AC-044E Report number: BCT07AR-044E

Bontek Compliance Laboratory Ltd hereby declares that testing has been completed and reports have been generated for:

Applicant: **NEW WISDOM INVESTMENT LIMITED**
4-306, Xianglixincun, Hongli West Road, Shenzhen, China

Manufacture: **NEW WISDOM INVESTMENT LIMITED**
Building A1-4, Shenbao Industry Park, Longgang District, Shenzhen, China

Product: **PORTABLE CHARGER**

Model: **GWB-15**

Rating: **Input: 110-240VAC, 6W**

And, in accordance with the following applicable directives:
89/336/EEC Electromagnetic Compatibility (as amended)

That this product has been assessed against the following applicable standards;
**EMC EN 55014-1: 2000+A1: 2001+A2: 2002
EN 55014-2: 2001
EN 61000-3-2: 2000
EN 61000-3-3: 1995+A1: 2001**

Therefore, Bontek Compliance Laboratory Ltd hereby acknowledges that the applicant may issue a DECLARATION of CONFORMITY and apply the CE marking in accordance with European Union Rules.

Attestation by: 



Andrew He Date of Issued: January 25, 2007

Rm 802-804, Jinmin Bld, Zizhu 6th Rd., Zhuzi Lin, Futian, Shenzhen 518040, Guangdong, P. R. China
Tel: 86-755-82871080 Fax: 86-755-82871368 Http://www.bontek.com.cn